

EMC 4 Cable Glands Brass

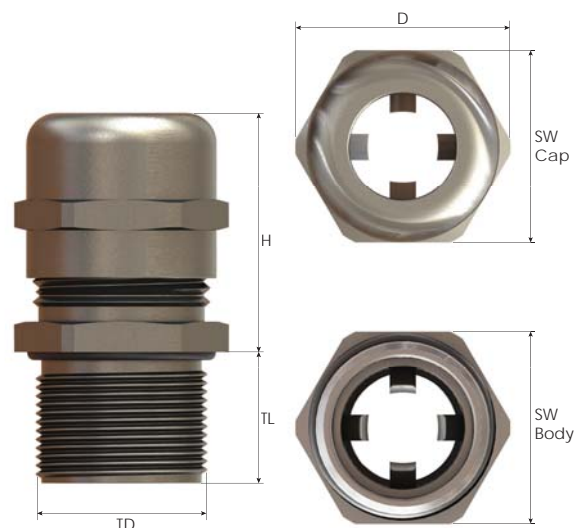

Thread Type **METRIC** acc. to EN 60423

Size	Clamping Range Ø min-max mm	Shield Diameter Ø min-max mm	Thread Length TL mm	Thread Ø TD mm	Spanner Width		Outer Ø D mm	max. Height H mm	Part Number	Packing Unit
					SW Cap mm	SW Body mm				
M12x1,5	3,0 - 6,5	2,0 - 5,0	6,0	12,0	14	14	15,5	28,0	BMEM-ES(M12T)	50
M16x1,5	5,0 - 10,0	3,5 - 8,0	6,0	16,0	20	20	22,0	33,0	BMEM-E1(M16T)	50
M20x1,5	6,0 - 12,0	4,5 - 10,0	6,0	20,0	22	22	24,5	32,0	BMEM-E2S(M20T)	50
	7,5 - 14,0	5,5 - 11,5	8,0		24	26	26,8	40,0	BMEM-E2(M20T)	
M25x1,5	10,0 - 18,0	7,0 - 14,0	8,0	25,0	30	30	33,0	43,0	BMEM-E3(M25T)	25
M32x1,5	16,0 - 25,0	12,0 - 20,0	9,0	32,0	40	40	43,5	53,0	BMEM-E4(M32T)	25
M40x1,5	22,0 - 32,0	18,0 - 27,0	9,0	40,0	50	50	55,5	60,5	BMEM-E5(M40T)	20
M50x1,5	30,0 - 38,0	26,0 - 34,0	9,0	50,0	58	58	64,0	73,0	BMEM-E6(M50T)	12
M63x1,5	34,0 - 44,0	30,0 - 40,0	14,0	63,0	64	68	75,0	59,0	BMEM-E7(M63T)	12
	37,0 - 53,0	33,0 - 49,0	10,0		75	75	83,0	75,0	BMEM-E7L(M63T)	